



- The fast "Spot-on" synchroniser
- LEAD and/or LAG synchronising facility
- Breaker closing time compensation
- Frequency differential analogue output
- "Easy view" status presentation
- Generator speed control (relays)
- Generator speed reference (analogue output)
- System status output

Specifications

Monitored Voltage Input:	100-120, 200-240, 380-415, or 440-460VAC, 40-70Hz (Fuse 0,5A)
Optional Aux. Supply (Only for KSQ104G2)	AC: 100-120, 200-240, 380-415, or 440-460VAC, 40-70Hz (Fuse 0,5A) DC: 24, 48 or 110VDC (Fuse 2A)
Contact Rating:	AC: 100VA - 250V/2A max. DC: 50W - 100V/1A max.
Adjustments:	High voltage: 2-15% of net voltage Low voltage: 2-15% of net voltage Frequency diff: 0,1-2Hz CB closing time: 30-300mS Pulse rate: 12-60 pr min Pulse width: 120mS to 1,6secs
*Analogue output:	-10/0/+10mADC = -5/0/+ 5Hz difference
*Optional output:	-10/0/+10VDC (same Hz range) <i>*Only active when Sync. mode is selected</i>
Temperature:	-20 to +70°C
Weight:	0.7kgs
Front protection:	IP52 (IP65 optional)

Unit meets IEC60092-504 and relevant environmental and EMC tests specified in IEC60068/60092 and IEC61000/60533 respectively, to comply with Classification Societies requirements.

Megacon is the inventor of the original, now industry standard "rotating" LED display, and a trendsetter in modern synchronisation control.

Description

The digitally controlled KSQ104x2 provides both visual presentation of voltage differential and relative speed and phase angle relationship and speed control output signals necessary to achieve fast automatic "spot-on" synchronising between two systems. KSQ104x2 is a direct replacement for the "traditional" KSQ104 and KSQ105.

Its many important features contribute to make KSQ104x2 simply the best choice available for synchronising in any automatic generator control system (PM-system).

KSQ104F2 is the standard and it takes the auxiliary voltage from the monitored voltage on terminal 3 & 4. KSQ104G2 have separate auxiliary supply on terminal 19 & 20.

Applications

KSQ104x2 is used for both single and three phase systems. Any two phases (or phase-neutral) can be used for synchronising as long as they are the same two phases on both sides of the breaker. The synchroniser is rated for continuous operation and can be left connected when not in use.

Synchronising modes

To adapt the functionality of KSQ104x2 to any specific application, the direction of approach to synchronising (LEAD, LAG or NEUTRAL) can be selected as required:

LEAD (incomer faster than bus), **LAG** (incomer slower than bus), **NEUTRAL** (bi-directional)

LEAD is generally the preferred mode. The synchronising relay will then operate when the frequency of the incomer is slightly HIGHER than the bus frequency. This is to avoid motoring of the incomer (entering reverse power condition) after the breaker is closed.

The rotary LED display and the direction of the yellow arrows indicate the incomer's speed relative to the bus. The rotary display is not lit if frequency difference between systems exceeds 5Hz.

Speed control

The raise/lower relays pulses the fuel control governor motor, or an interfacing MXR845x electronic potentiometer. Pulse length and rate of the speed control relays are adjusted on the rear of the unit to suit the dynamic response of any engine regulator. The speed control has a P/I (proportional/integral) characteristic, with a dynamically controlled dead zone.

Alternatively the linear analogue -10 / 0 / +10mA output signal can be used as speed reference to a generator controller, with polarity and amplitude proportional to frequency difference between the two systems when synchronising mode is selected.

System status:

KSQ104x2 is fitted with a system status relay. As standard the unit is powered from generator side (terminal 3 & 4), when power is ok and unit is working correctly the relay activates. It will release on alarm or when unit is not powered. Separate auxiliary supply is needed for continuously system status.

Normal operation : Closed contact
Alarm condition/unpowered : Open contact



Connection

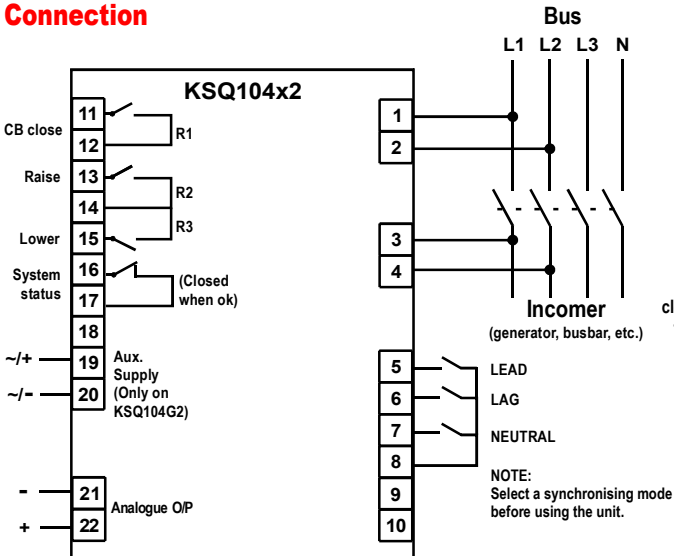

System "P"
"Spot-on" synchronising
LEAD direction

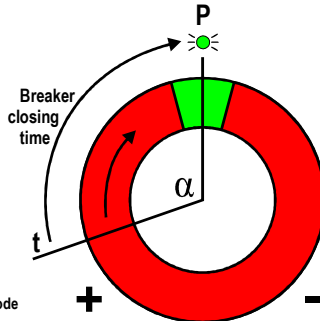

Fig.1

System "P"
"Spot-on" synchronising
LAG direction

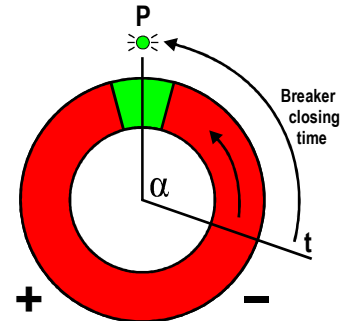

Fig.2

Description

“SPOT ON” synchronisation - CB closing time compensation

The dynamically controlled CB closing time compensation provides a **SMOOTH** synchronising, avoiding that the engine/generator couplings are exposed to excessive torque forces. Is **FAST** synchronisation the priority, an accurate "SPOT-ON" synchronising will still be maintained even with a high frequency difference between the power sources.

The System "P" synchronising principle

The relay closure is initiated at "T" when the breaker coil is energised and finalises at "P", assuring a precise "12 o'clock" synchronisation (figs 1 and 2). Allowed frequency difference is adjustable between 0.1Hz to 2Hz.

Typical setting for **smooth synchronising** is 0,2Hz. The angle "a" varies according to the calculated frequency difference between the two systems. The synchroniser operation and accuracy is not influenced by distorted voltage waveform or harmonics.

Synchronisation

Green lamps indicate voltage presence on reference source (BUS PWR, only when generator is powered) and incoming generator (GEN PWR). Green lamps also indicate that voltage and frequency differential between the two systems are within the limits. The synchronising relay will close when above conditions are achieved.

A green lamp (CB close) indicates the closing command to the breaker. Frequency difference and voltage limits, circuit breaker closing time, speed control relays pulse length/rate and synchronising mode are user settable on unit rear.

Dimensions

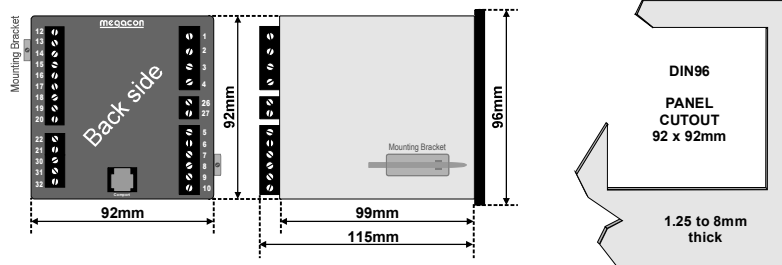

The MEGAICON policy is one of continuous improvement, consequently equipment supplied may vary in detail from this publication.

ORDERING INFORMATION

Product type : KSQ104G2
Auxiliary supply : 230VAC
Network voltage : 450VAC

