

T4800 Load Sharer

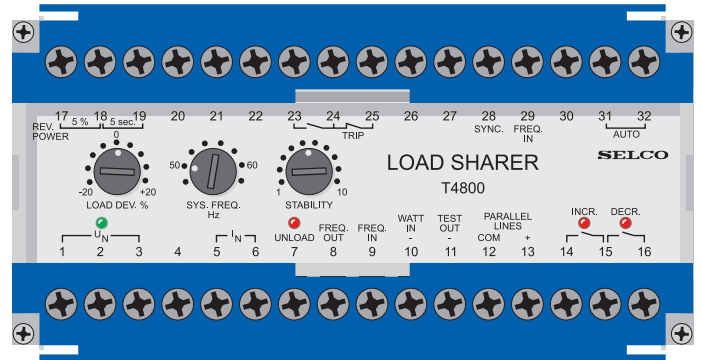

- Automatic load sharing with relay outputs for speed control
- 2-wire communication with other T4800 Load Sharers
- System frequency control
- Unload facility
- Reverse power and unloaded trip
- Visual indication of voltage, increase, decrease and unload signals
- Cost effective and highly reliable compact design
- 50 hours burn-in before final test
- Vibration test up to 4g RMS
- Certified by major marine classification societies
- Flame retardant enclosure



Application

The T4800 Load Sharer provides automatic load sharing and system frequency control for parallel running generators. The load sharing is proportional, meaning that the generators will be loaded equally compared to their individual capacity.

The load on each generator is compared with the load on the other generators and corrected until balance is obtained. Load sharing is necessary after synchronization in order to re-establish load balance and to obtain long term stability of load and system frequency.

When applied with the B9300 Power Reference Unit, one or several generators can be operated in parallel with the grid (utility).

Together with the T4500 Auto Synchronizer, the T4800 provides the optimal solution for generator control, both in marine and land-based applications. The T4800 is type approved by major marine classification societies. The T4900 VAR-Load Sharer can also be used as a supplement. The combination of the T4800 and the T4900 will provide complete load sharing of both active load and reactive load.

Function

The input to the T4800 is the voltage and current, from which the active load and frequency are determined. The T4800 calculates $I \times \cos \phi$, representing the active load. The load on each generator is compared with the load on the other generators. Contact signals for increase and decrease with proportional pulses are obtained as output. These pulses regulate the frequency and load via the electric servomotor on a conventional speed governor, or by controlling an electronic speed controller via an intermediate E7800 Motorized Potentiometer.

The speed governor must operate with

droop (frequency decrease with load increase) in order to obtain fast load balance with load changes.

An unload function is also provided. When activated, the T4800 will reduce the generator load to zero. A built-in relay can automatically trip the circuit breaker when the unload procedure is completed.

The T4800 has a built-in reverse power protection with selectable limits and time delays.

Supply voltage / current

The supply voltage from L1 and L2 is connected to terminals 1 and 3 or 2 and 3, depending on the system voltage.

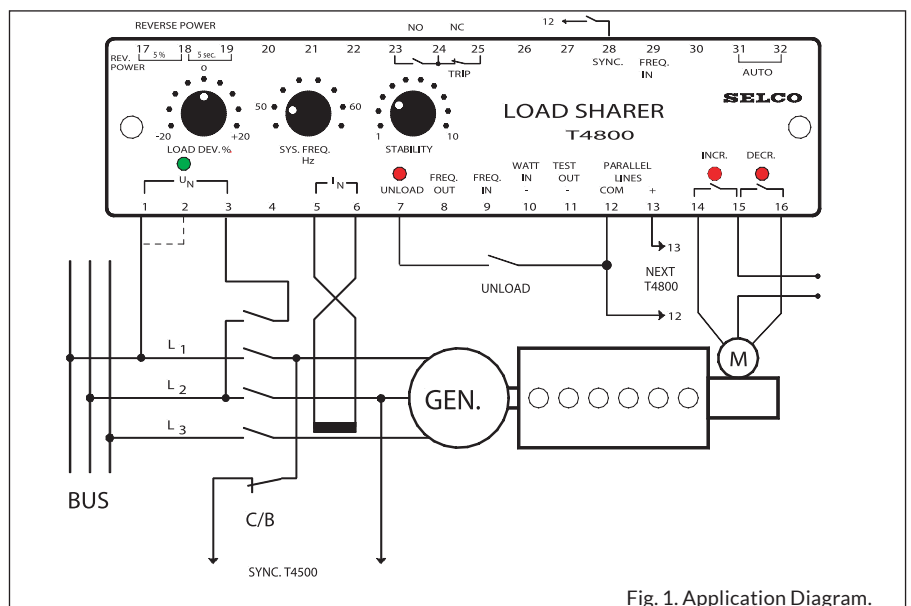

Fig. 1. Application Diagram.

The measuring current from L3 is connected to terminals 5 and 6 with 5 referring to the generator (see the diagram figure 1).

The current measurement must be taken from the same phase on all generators. The current is measured in the phase that is not supplying the unit. It is important to ensure that the phase sequence is correct.

This relation between the connections of voltage and current must be correct in order to achieve a correct load measurement. It can be checked on terminal 11 (TEST OUT), where an input of nominal current (1A or 5A) and power factor 1.0 gives -2.0V for correct connection.

Common reference

Terminal 12 (COM.) is common reference for all terminals 7 to 13 and 28 to 29.

Power and frequency balance

Two normally de-energized relays (INCR. and DECR.) with LED indications on terminals 14, 15 and 16, are for increase and decrease pulses to the governor servo motor or to an intermediate E7800 Motorized Potentiometer (controlling the speed trim input of an electronic speed controller). The width of the pulses is proportional to the frequency / load difference.

Communication between load sharers

For communication between the load sharers all terminals 12 (COM.) are interconnected, as well as all terminals 13 (+).

Unload

Connecting terminals 7 (UNLOAD) and 12 will reduce the power on the generator to zero load, and maintain zero load. When the load passes below 5% load, a trip signal is provided as a normally open (NO) contact on terminals 23-24 and a normally closed (NC) contact on terminals 24-25. This trip signal can be used to trip the circuit breaker.

Frequency out

Connecting terminal 8 (FREQ. OUT) to terminal 12 will disable the frequency control and can be used when running in parallel with the grid where the frequency is fixed by the grid.

Note: When using the B9300 Power Reference Unit, connected to the parallel lines (terminals 12 and 13) of the T4800, the frequency control will automatically be disabled. In such situations it is not nec-

essary to connect terminal 8 to terminal 12 for disabling the frequency control.

Frequency in / sync. control

An external voltage injected between terminals 9 (FREQ. IN) and 12 can control the frequency. The same signal can be connected between terminals 29 (FREQ. IN) and 12. The synchronizing control on terminal 28 (SYNC.) will switch this signal on and at the same time disable the internal frequency control.

This feature can be used for simultaneous synchronization of already parallel running generators to another busbar section, a shaft generator or the grid. An output from terminals 12 (COM) and 13 (FREQ. OUT) on the T4500 connected to terminals 12 (COM) and 29 (FREQ. IN) on all the T4800 Load Sharers will allow the frequency to be aligned for synchronizing.

Terminals 28 (SYNC.) on all load sharers are interconnected and with a contact between terminals 28 and 12, the external frequency signal from T4500 Synchronizer on terminal 29 will be active and all internal frequency controls are disabled (see application diagram figure 3).

Watt in

Between terminals 10 (WATT IN) and 12 a negative voltage -1.0V from a volt free watt converter can be connected to substitute the internal load measuring circuit. In this case no current transformer (CT) needs to be connected to terminals 5 and 6. Most standard measurement signals can be adapted with external resistors.

0 - 10V : Series resistor 820kΩ
0 - 5mA : Parallel resistor 200Ω

Reverse power trip / unload trip

The reverse power trip operates at 10% with a delay of 10 sec., but it can be reduced to 5% by bridging terminals 17 and 18 and to 5 sec. delay by bridging terminals 18 and 19. A resistor of 510kΩ between terminals 17 and 18 gives 7.5%, a resistor of 2.7MΩ between terminals 18 and 19 gives 7.5 sec. delay.

If the generator is unloading (contact between terminals 7 and 12) a trip signal is obtained when the load passes below +5% load.

Both tripping signals are available on the same potential free contact set, normally

open (NO) contact on terminals 23-24 and normally closed (NC) contact on terminals 24-25. The reverse power trip signal is continuous, and the unload trip signal has a duration of 0.5 sec.

Auto mode

Terminals 31 and 32 (AUTO) must be bridged for automatic load sharing function. If only reverse power protection is wanted, the terminals should be disconnected.

Adjustments

LOAD DEV. can be used for fine adjustments of the load balance. It should also be used to obtain balance with generators of different size and with different types of CTs. For generators of the same size and with the same type of CT the setting 0 should be used on all load sharers.

SYS. FREQ. is used for adjustment of the system frequency. It can be adjusted between 48Hz and 62Hz.

STABILITY is used for adjusting the regulation time. A high setting of STABILITY will give a slow, but accurate regulation. A low setting will give a fast regulation. However, too low a setting may cause instability.

With the STABILITY adjustment the proportional band (pulsing band) is adjustable between ±50 - 250% load and ±5 - 25% frequency, and the dead band zone (in balance - no pulsing) is adjustable between ±2 - 10% load and ±0.2 - 1.0% frequency.

Trouble Shooting

If load balance is not obtainable
If load balance is not obtainable and the load goes to maximum or reverse power, one of the signals is inverted due to wrong polarity or interchanged wires. If this is the case, the following should be checked:

1. The polarity of the power measuring signals on terminal 11 (TEST OUT) must be positive with the generator on load. If the polarity is positive, change the voltage connections 1 and 3 or 2 and 3 or the current connections 5 and 6.
2. Increase and decrease outputs should be obtained as indicated by the LEDs on the front.
3. The parallel lines connected to 12 (COM.) and 13 (+) between load sharers must not be interchanged.

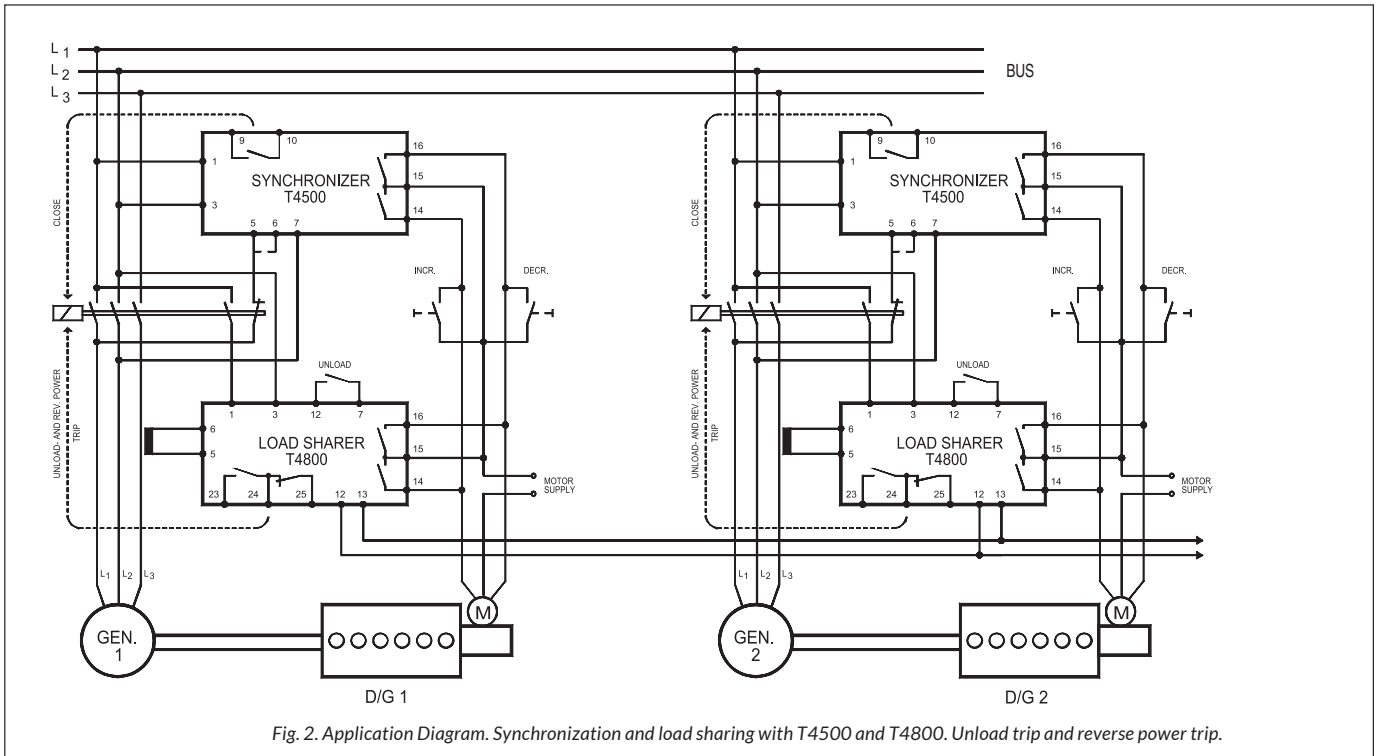

Fig. 2. Application Diagram. Synchronization and load sharing with T4500 and T4800. Unload trip and reverse power trip.

If the load balance is incorrect.

If there is a balance point, but the load balance is incorrect, the following should be checked:

1. Load deviation shall be set to 0 for same size of generators and same type of CTs.
2. If the deviation from other generators is approximately two times, it is likely that the current on terminals 5 and 6 is measured in one of the phases supplying the T4800. The current must be measured in the phase that is not supplying the unit (see the application in fig. 1).

Check the voltage on terminal 11 (TEST OUT) to be -2.0V DC for nominal current input (IN=1A or IN=5A) and power factor = 1.0. A current measurement in a wrong phase will give +1V DC.

Example:

If the current in terminals 5 and 6 is 2.0A, the nominal current IN is 5A, and the power factor is 0.8, then the voltage for correct connection is:

$$-2 \times \frac{2}{5} \times 0.8 = -0.64V.$$

If the load is fluctuating up and down
 If there is a correct balance point, but the load is fluctuating up and down, the STABILITY should be turned clockwise in order to obtain stability, but not more than necessary.

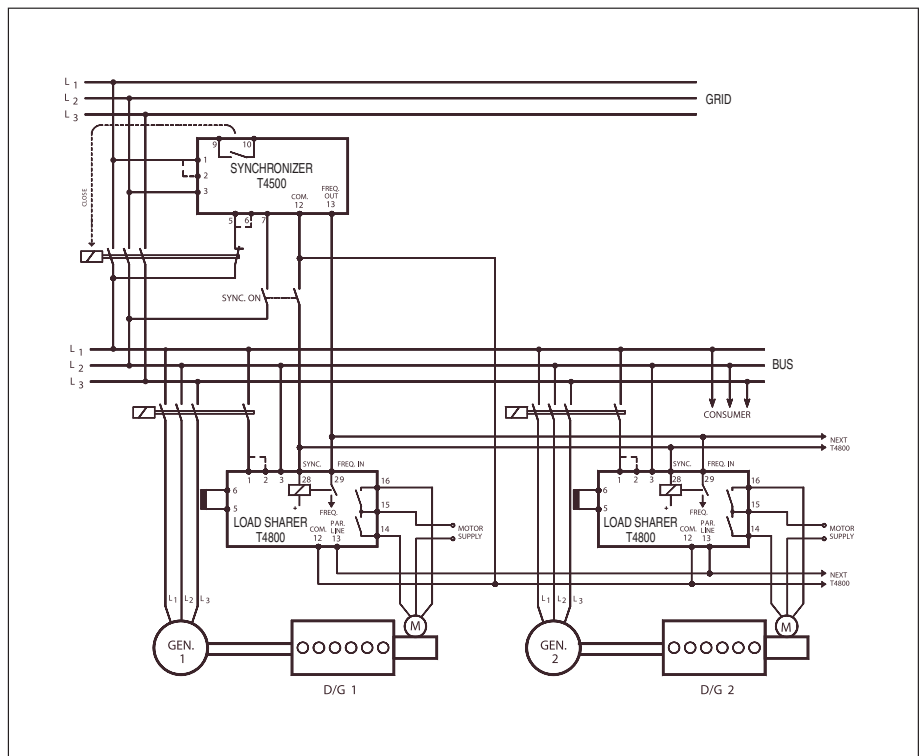

Specifications

T4800 Load Sharer

Max. voltage	660V
Voltage range	70 - 110%
Consumption	Voltage 4VA at U_N Current 0.4VA at I_N
Continuous current	$2 \times I_N$
Frequency range	35 - 70Hz
Frequency adjustment	48 - 62Hz
Proportional band	± 50 - 250% load ± 5 - 25% frequency
Dead band zone	± 2 - 10% load ± 0.2 - 1.0% frequency
Contact rating	AC: 400V, 2A, 250VA DC: 110V, 2A, 100W
Operating temperature	-20°C to +70°C
Vibration test	4g RMS according to IEC 60068-2-64
EMC	According to IEC/EN 61000-6-1/2/3/4
Approvals	Certified by major marine classification societies
Burn-in	50 hours before final test
Enclosure material	Polycarbonate, flame retardant
Weight	0.7kg
Dimensions	70 x 150 x 115mm (H x W x D)
Installation	35 DIN rail or two 4mm (3/16") screws

The specifications are subject to change without notice.

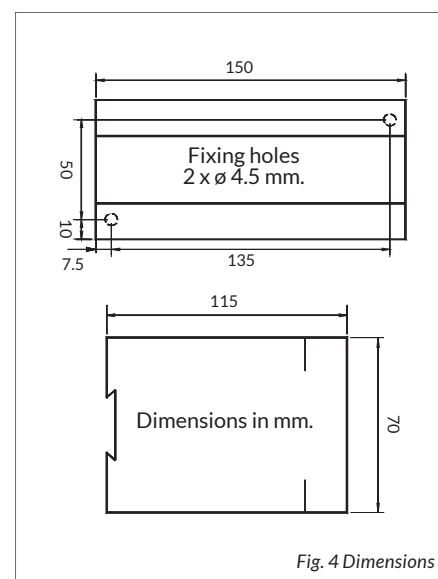

Fig. 4 Dimensions

Type Selection Table

Standard types: $I_N = 5A$

Type	Terminals		I_N
	1-3	2-3	
T4800.0010	450V	400V	5A
T4800.0020	230V		5A
T4800.0030	480V	415V	5A
T4800.0040	110V	100V	1A
T4800.0050	450V	400V	1A
T4800.0060	127V	120V	5A
T4800.0070	110V	100V	5A

Other supply voltages, nominal currents and combinations are available on request.

Approvals & Certificates

The T4800 has been approved by major marine classification societies.

For more information about the individual certificates, please visit selco.com

