

T4900 VAr Load Sharer

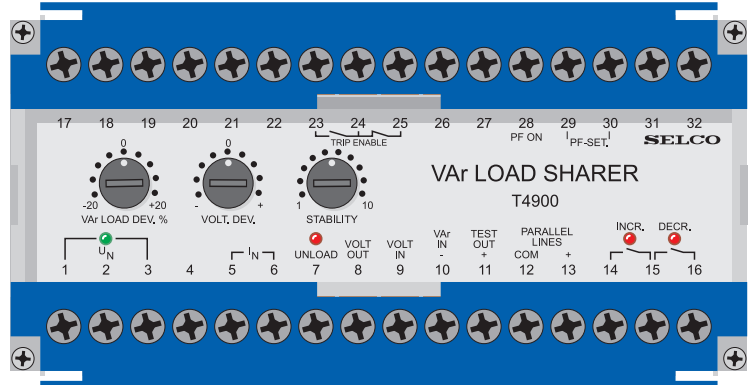

- Automatic load sharing of reactive power
- Voltage control facility
- 2-wire communication with other T4900 VAr Load Sharers
- Power factor control when running in parallel to the grid
- Unload and trip facility
- Visual indication of voltage, increase, decrease and unload signals
- Cost effective and highly reliable compact design
- 50 hours burn-in before final test
- Flame retardant enclosure



Application

The T4900 VAr Load Sharer provides automatic load sharing of reactive power and voltage control for parallel running generators.

The reactive load on each generator is compared with the reactive load on the other generators and corrected on the AVR (Automatic Voltage Regulator) via a motorized potentiometer (e.g. the SELCO E7800) until balance is obtained.

Reactive load sharing is important in systems with many inductive loads, operating with relatively low power factors. In such systems the reactive kVAr load is relatively large. The T4900 can be used for sharing this reactive load component between the generators. Additionally, the T4900 will provide voltage stability with increased kVAr load.

The T4900 can also be used for power factor (PF) control in applications where one or more generators are operated in parallel with the grid (utility).

Together with the T4400 Load Sharer or the T4800 Load Sharer, the T4900 VAr Load Sharer provides the optimal solution for automated generator control, both in land and marine-based applications. The combination of the T4800 and the T4900

will provide complete load sharing of both active and reactive load.

Function

The input to the T4900 is the voltage and the current from which the reactive power and voltage is determined.

The T4900 calculates $I \times \sin f$, representing the reactive kVAr load. The reactive load on each generator is compared with the reactive load on the other generators. Contact signals for increase and decrease with proportional pulses are obtained as output. These pulses regulate the voltage and reactive load by controlling the AVR via an intermediate E7800 Motorized Potentiometer.

An unload function is also provided. When activated, the T4900 will reduce the generator reactive power to zero or the power factor to 1.0.

Power factor control for parallel operation with the grid can be obtained by connecting an external contact between terminals 12 (COM) and 28 (PF ON). The setting is determined by an external potentiometer (100kW) across terminals 29 and 30 (PF-SET).

Supply voltage / current

The supply voltage from L1 and L2 is connected to terminals 1 and 3 or 2 and 3, depending on the system voltage.

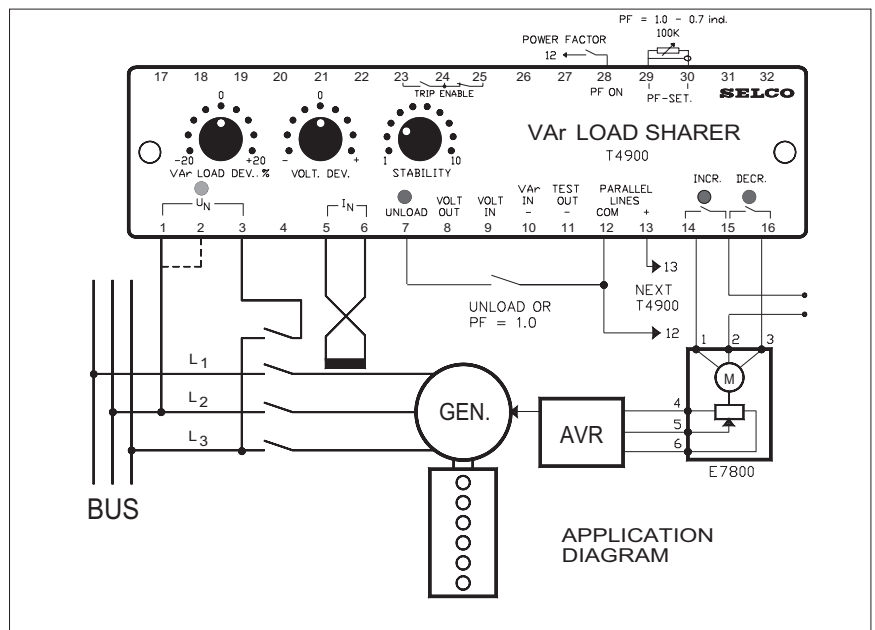

The measuring current from L1 is connected to terminals 5 and 6 with 5 referring to the generator (see the diagram in figure 1). The current measurement must be taken from the same phase on all generators. The current is measured in the phase that is not supplying the unit. It is important to ensure that the phase sequence is correct.

This relation between the connections of voltage and current must be correct in order to achieve a correct load measurement. It can be checked on terminal 11 (TEST OUT), where an input of nominal current (1A or 5A) and power factor 1.0 gives -2V for correct connection.

Common reference

Terminal 12 (COM.) is the common reference for terminals 7 to 13.

Reactive power and voltage balance

Two normally de-energized relays (INCR. and DECR.) with LED indications, on terminals 14, 15 and 16, are for increase and decrease pulses to the motorized potentiometer. Via the motorized potentiometer, the setting of the automatic voltage regulator (AVR) is done in order to regulate the reactive power with optimum speed and stability.

The width of the pulses is proportional to the voltage / KVar load difference

Communication between load sharers

For communication between the reactive load sharers all terminals 12 (COM.) are interconnected, as well as all terminals 13 (+).

Unload

Connecting terminal 7 (UNLOAD) and terminal 12 will reduce the reactive power on the generator to zero and maintain zero reactive power. If the unit is in power factor control, the power factor will be adjusted to 1.0.

Voltage out

Connecting terminal 8 (VOLT OUT) to 12 will disable voltage control and is used when running in parallel with the grid, where the voltage is fixed by the grid.

VAr in

Between terminals 10 (VAr IN) and 12 a negative voltage -1.0V from a volt

free VAr converter can be connected to substitute the internal reactive power measuring circuit. In this case no current transducer needs to be connected to terminals 5 and 6. Most standard measurement signals can be adapted with external resistors

0 - 10V : Series resistor 820k Ω

0 - 5mA : Parallel resistor 200 Ω

Power factor control

A contact between terminal 28 (PF ON) and terminal 12 will change the function from Var load sharer to power factor controller. A variable resistor between terminal 29 and terminal 30 of 100k Ω determines the power factor from 1.0 to 0.7 inductive. Zero Ω gives a power factor of 1.0, increasing resistance will give decreasing power factor.

A contact between terminals 7 (UNLOAD) and 12 will regulate the power factor to 1.0, independent of the selected power factor on terminals 29-30.

Trip enable

If the generator is unloading (contact between terminals 7 and 12) a trip signal is obtained when the reactive load passes below +5%. In power factor control mode the trip signal is obtained when the power factor approaches 1.0.

The tripping signals are available on the potential free contact set, normally open (NO) contact on terminals 23-24 and normally closed (NC) contact on terminals 24-25.

Adjustments

VAr-LOAD DEV. can be used for fine adjustments of the KVar load balance.

It should also be used to obtain balance with generators of different sizes and with different types of current transducers (CTs). For generators of same size and with same type of CT, the setting 0 should be used on all load sharers.

VOLT. DEV. can be used for adjustment of the generator voltage. An adjustment of approximately $\pm 12\%$ from nominal voltage is possible.

STABILITY is used for adjusting the regulation time. A high setting of STABILITY will give a slow but accurate regulation. A low setting will give a fast regulation.

However, too low a setting may cause instability.

With the STABILITY adjustment the proportional band (pulsing band) is adjustable between 25 and 125% and the dead band zone (in balance - no pulsing) is adjustable between 1 and 10%.

Trouble shooting

If the KVar load balance is not obtainable

If the KVar load balance is not obtainable and the reactive load is only increasing or decreasing continuously, one of the input signals is inverted due to wrong polarity or interchanged wires. If this is the case, the following should be checked:

1. The polarity of the KVar power measuring signal on terminal 11 (TEST OUT) must be negative for inductive load. If the polarity is positive, change the voltage connections 1 and 3 or 2 and 3 or the current connections 5 and 6.
2. Increase and decrease outputs should be obtained as indicated by the LEDs on the front.
3. The parallel lines connected to terminals 12 (COM.) and 13 (+) between load sharers must not be interchanged

If the KVar load balance is incorrect

If there is a balance point, but the KVar load balance is incorrect, the following should be checked:

1. Load deviation should be on zero for identical generators and installations. Small differences can be corrected here.
2. If the deviation from other generators is approximately two times, it is likely that the current on terminals 5 and 6 is measured in one of the phases supplying the T4400. The current must be measured in the phase that is not supplying the unit (see the diagram on page 1).

If the KVar load is fluctuating up and down

If there is a correct balance point, but the KVar load is fluctuating up and down, the STABILITY should be turned clockwise to obtain stability, but not more than necessary. STABILITY should be turned clockwise in order to obtain stability, but not more than necessary.

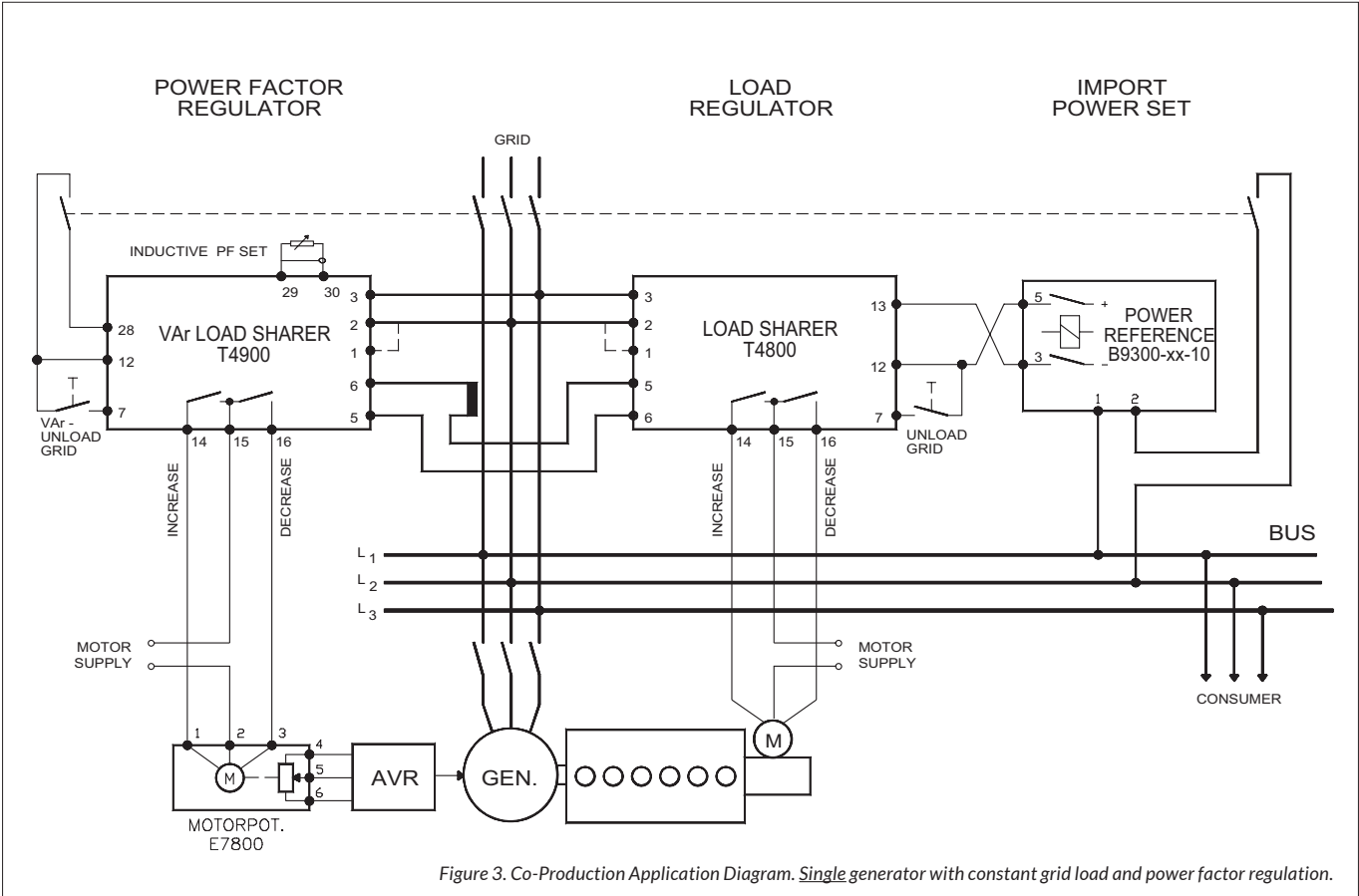
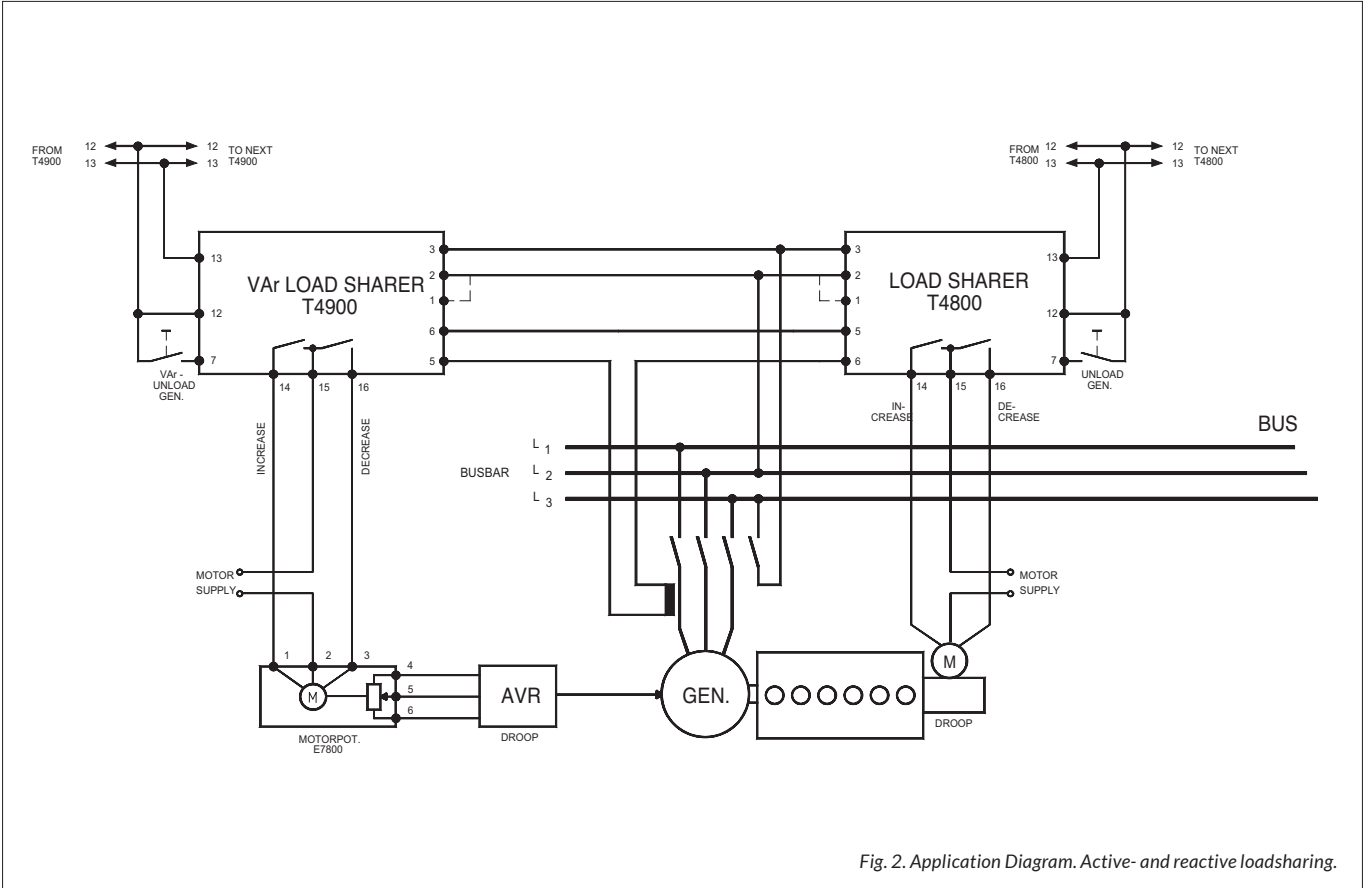

Specifications

T4900 VAr Load Sharer

Max. voltage	660V
Voltage range	110%
Voltage dev. adjustment	0 - ±12V
Consumption	Voltage 4VA at U_N Current 0.4VA at I_N
Continuous current	$2 \times I_N$
Frequency range	35 - 70Hz
Proportional band	±25 - 125% load
Dead band zone	±1 - 10% load
Contact rating	AC: 400V, 2A, 250VA DC: 110V, 2A, 100W
Operating temperature	-20°C to +70°C
EMC	According to IEC/EN 61000-6-1/2/3/4
Burn-in	50 hours before final test
Enclosure material	Polycarbonate, flame retardant
Weight	0.7kg
Dimensions	70 x 150 x 115mm (H x W x D)
Installation	35 DIN rail or two 4mm (3/16") screws

The specifications are subject to change without notice.

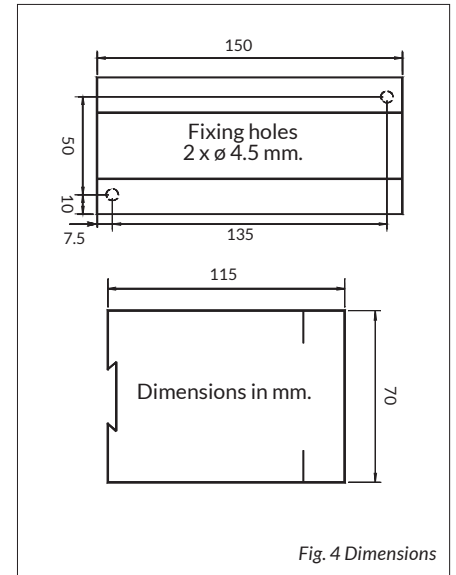

Type Selection Table

Standard types: $I_N = 5A$

Type	Terminals		I_N
	1-3	2-3	
T4900.0010	450V	400V	5A
T4900.0020	230V		5A
T4900.0030	480V	415V	5A
T4900.0040	110V	100V	5A
T4900.0050	110V	100V	1A
T4900.0060	450V	400V	1A

Other supply voltages, nominal currents and combinations are available on request.

Approvals & Certificates

The T4900 has been approved by major marine classification societies.

For more information about the individual certificates, please visit selco.com

