



- Designed for non-grounded networks with Frequency Converters
- Direct connection up to 690V line voltage, up to 1,4kV with HV Adapter
- Monitoring during both live and standby conditions
- For use in land, marine and offshore Installations
- Complies with IMCA D 045 Code of Practice
- "Megger" - safe to 1.4kVDC when aux power is OFF
- Immune to earth capacitance and voltage surges
- Analogue output proportional to meter reading

Specifications

Auxiliary Supply:	100-120, 200-240, 380-415 or 440-460VAC, 40-70Hz (Fuse 0.5A)
Optional Voltage:	12-24, 48 or 110VDC (Fuse 2A)
Supply tolerance:	± 10%
Power rating:	1,5VA
Contact rating:	AC: 100VA - 250V/2A max. DC: 50W - 100V/1A max.
Analogue Output:	Up to 20mA, max 500R
F-versions	Up to 10V, min 100kohm (other on request)
Temperature:	-20 to +70°C
Weight:	0.85kgs
Front protection:	IP52 (IP65 optional)

INTELLIGENT SETTING ASSISTANCE

KPM161FQx has a built-in Assistance tool for setting/verification of the trip levels and the analogue output.

When either the **Warning** or **Alarm** potmeter on the rear is operated by user, the meter goes into **Assistance Mode** and meter reading and analogue output will reflect the potmeter setting.

How to set alarm levels:

Firstly adjust potmeter fully clockwise (see that meter goes to the top), then adjust potmeter down to required **Warning** or **Alarm** setpoint. In this mode, the Alarm or Warning LEDs (depending on which potmeter is adjusted) will flash quickly Red/Yellow.



Without any movement of potmeters, the meter will revert to normal Insulation Monitoring Mode after approximately 10 seconds.

How to test analogue output signal:

Adjust any trip level potmeter to activate Assistance Mode. **Example:** On a 4-20mA output, adjust potmeter fully anti clockwise for 4mA and fully clockwise for 20mA.

The KPM161FQx range is designed to comply with specification IMCA D 045 "Code of Practice for the Safe Use of Electricity Under Water" issued by IMCA.

The unit meets EN 61010-1 Cat. III, Pollution degree 2 and the relevant environmental and EMC tests specified in EN 61326-2-4 to comply with the requirements of the major Classification Societies.

Application

The digitally controlled KPM161FQx is designed to monitor the insulation level between a non-grounded (IT) AC mains and its protective earth in systems with frequency converters. The unit is for land, marine and offshore use.

An AC or DC auxiliary voltage is required for the unit, if powered from a separate source the network can also be monitored during inactive (standby) conditions. Only **ONE** KPM161FQx can be connected to each IT-system. The ohmmeter and the triple-zone status LEDs give at a glance the clear safety message:

- ALARM (red zone)
- WARNING (yellow zone)
- HEALTHY (green zone)

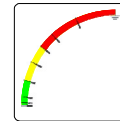

General

IDV MEASURING PRINCIPLE

Insulation is measured between the complete galvanically interconnected AC network and its protective earth.

The unit injects a DC measuring signal into the monitored system. The signal flows to ground via the path of the insulation fault, the level of flow indicates the insulation resistance. The measuring accuracy is not influenced by any normal kind of load attached to the AC network.

This unit is used for any land, marine or offshore installations. Start of monitoring function is delayed when auxiliary power is switched on (default 5 secs delay). The unit has minimum of 9 seconds detection time for any insulation fault.

Trip levels and delays are settable on unit rear. A trip LED flashes when the trip level is passed, the relay trips when the delay has elapsed. The timer resets if the fault is removed during countdown.

MEGGER SAFE

When auxiliary power is **OFF** the unit input is automatically protected against "megger" test voltages up to 1.4kVDC, and incorrect measurements caused by the unit's input impedance are avoided.

OUTPUTS

The KPM161FQx has an isolated **analogue output** proportional to meter reading. If output is used for remote meter reading, we recommend 0-1mA for the slave indicator.

SAFETY

When a voltage adaptor (CHx) is used the signal to terminals 4 and 6 on KPM161FQx is limited to a safe level, avoiding any dangerous voltage exposure to personnel.

HIGH VOLTAGE ADAPTOR

Voltage Adaptor CH163-1,4 is used for Insulation Guard KPM161FQx when the monitored line voltage is higher than 690VAC.



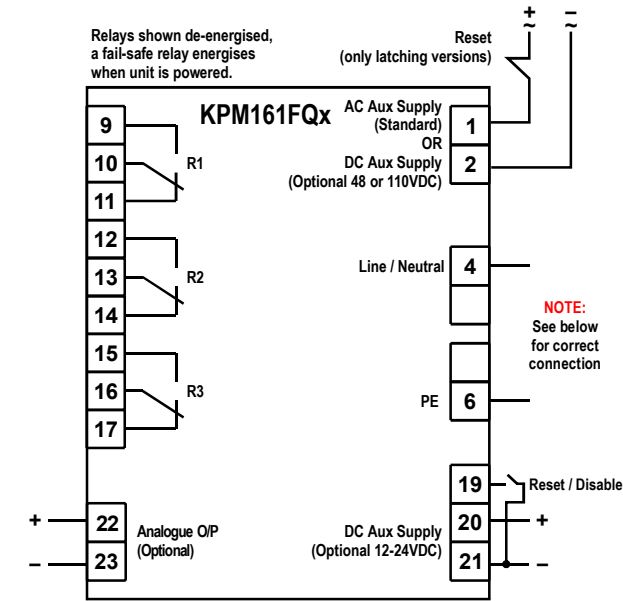

Analogue Output

KPM161FQ and KPM161FQG have an analogue output proportional to meter reading. (Special outputs are available on request)

Add suffix from table below to type designation to specify output required:

O/P1	0 - 10mA	O/P6	N/A
O/P2	0 - 20mA	O/P7	N/A
O/P3	4 - 20mA	O/P8	0 - 10VDC
O/P4	N/A	O/P9	N/A
O/P5	N/A	O/P10	N/A

Reset / Paralleling Disable Function

KPM161FQx has a built-in disable function. When connecting two or more IT-networks together **only one unit** can be active, the other(s) must be disabled. When unit is disabled the power led will flash every 2 seconds to indicate that unit is inactive.

Use a potential free contact on terminal 19 & 21 to activate the disable function (after 2 secs). When activated the measuring input terminal 4 will be internally disconnected.

A pulse (60mS - 2 secs) on terminal 19 & 21 will only reset any latching alarm.

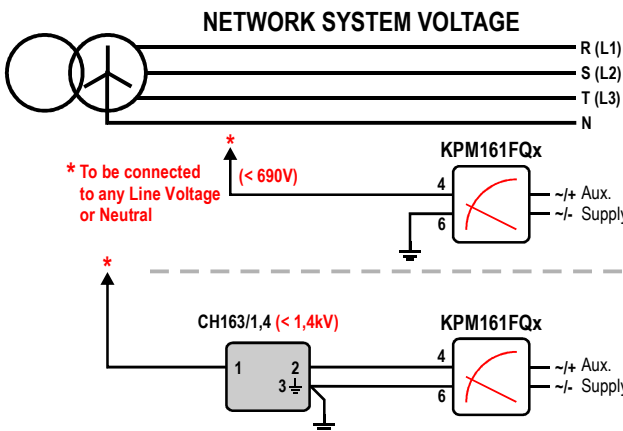

Dimensions

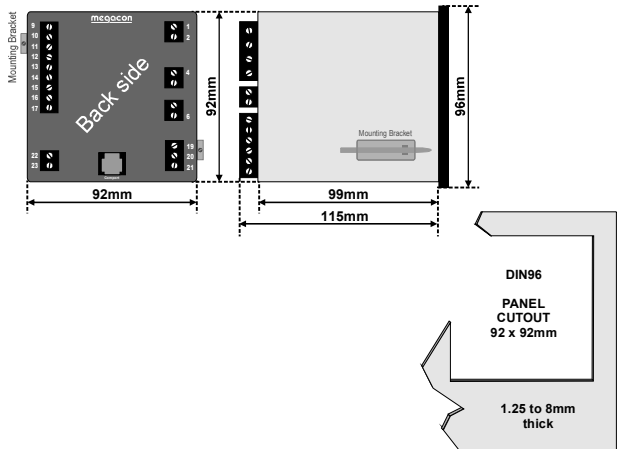

Description

KPM161FQ - KPM161FQG

This unit is used for industrial, marine and offshore installations with frequency converters. Start of monitoring function is delayed when auxiliary power is switched on (default 5 secs delay). The unit has a detection time of 6-9 seconds for any insulation fault.

Direct connection up to 690V line voltage. Up to 1,4kVAC via HV adaptor.

Coloured sectors show recommended areas of settings:
 red - Indicates alarm trip zone
 yellow - Indicates warning trip zone
 green - Indicates healthy zone

Output diagram

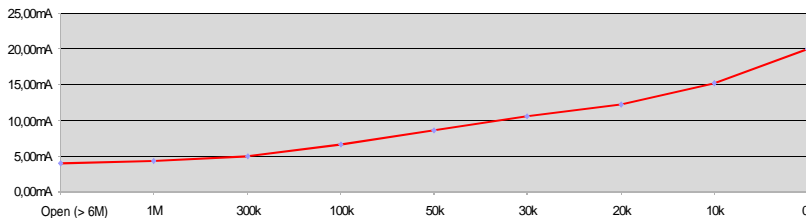

Relay Operation

Scale range: 0-1000kΩ - ∞ (>6MΩ)

	Warning	Alarm	Fail Safe	Latch
R1	✓			
R2		✓	✓	* / ✓
R3		✓		* / ✓

Model	Latch	Output	Adjustments	Trip level	Delay
KPM161FQ	-	X	WARNING:	0-1MΩ	0-30secs
KPM161FQG*	X	X	ALARM:	0-1MΩ	0,1-3secs

Output table (example for 4-20mA) Range

Value (scale)	mA output
0kΩ	20.00mA
10kΩ	15.22mA
20kΩ	12.32mA
30kΩ	10.61mA
50kΩ	8.68mA
100kΩ	6.69mA
300kΩ	4.98mA
1MΩ	4.28mA
Open (>6MΩ)	4.00mA

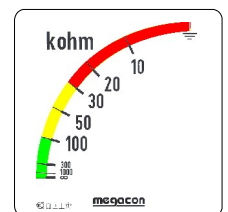

The MEGAICON policy is one of continuous improvement, consequently equipment supplied may vary in detail from this publication.

ORDERING EXAMPLE:

Type: KPM161FQ
 Aux. Supply: 200-240VAC
 Network Voltage: 690VAC
 Analogue O/P: (O/P3) 4-20mA
 Range: 0 - 1000kohm



Norway
 Denmark
 United Kingdom
megacon



www.megacon.com
 ELECTRONIC CONTROL AND INSTRUMENTATION

SELCOUSA.com

Innovation Beyond Tradition
 Uniquely MEGAICON, simpler it can't be!

